

# Headquarters U.S. Air Force

---

*Integrity - Service - Excellence*

## **Changes in Air Force M&S Governance** *(The Implementation of AF M&S “CHOKECON”)*



**U.S. AIR FORCE**

Col Marcus “Shaka” Boyd  
AFAMS/CC  
6 Jan 12  
Version 1.0

---



U.S. AIR FORCE

# AF M&S "CHOKECON"

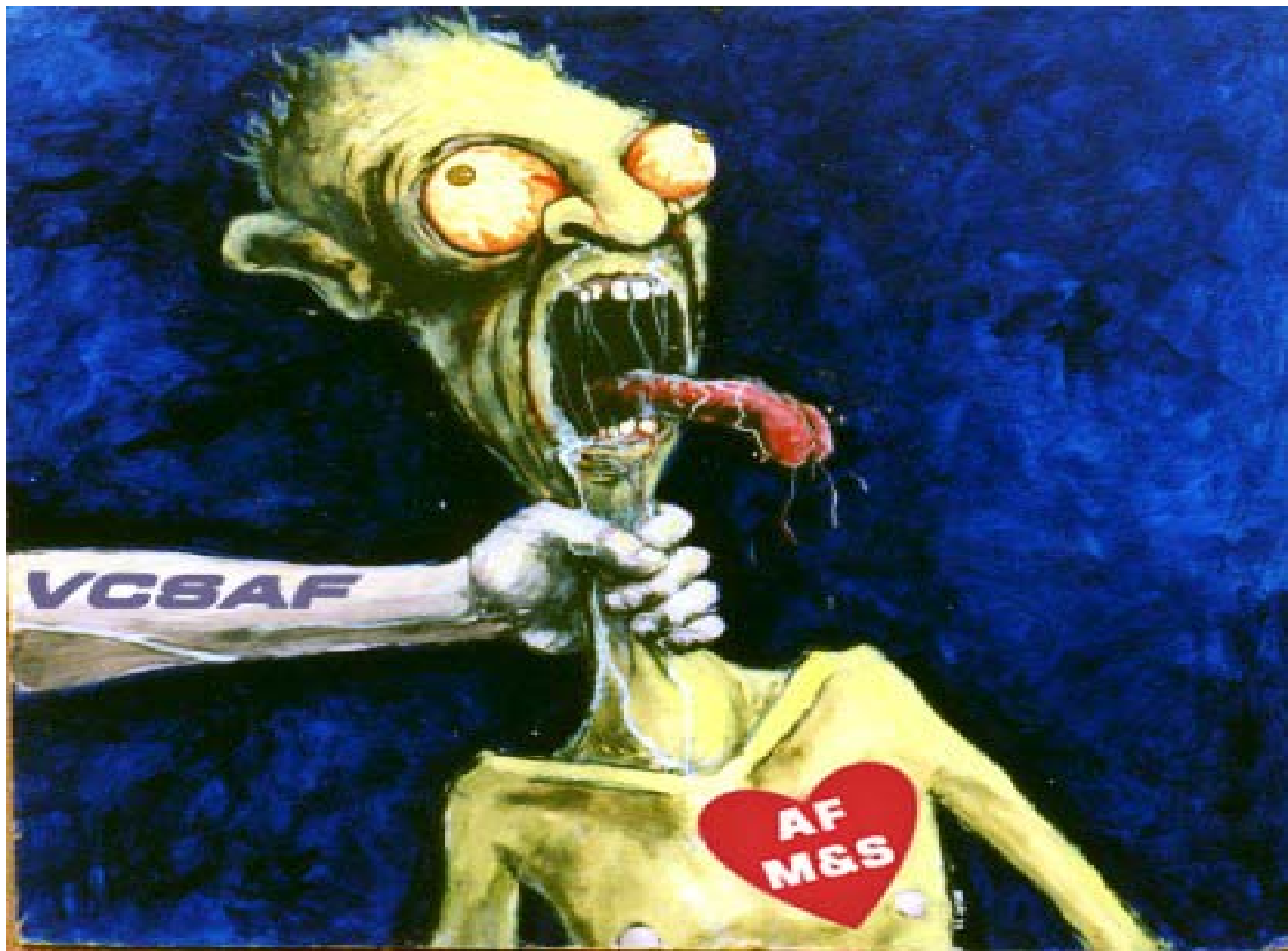

*Integrity - Service - Excellence*



# AF M&S Governance - Before

U.S. AIR FORCE

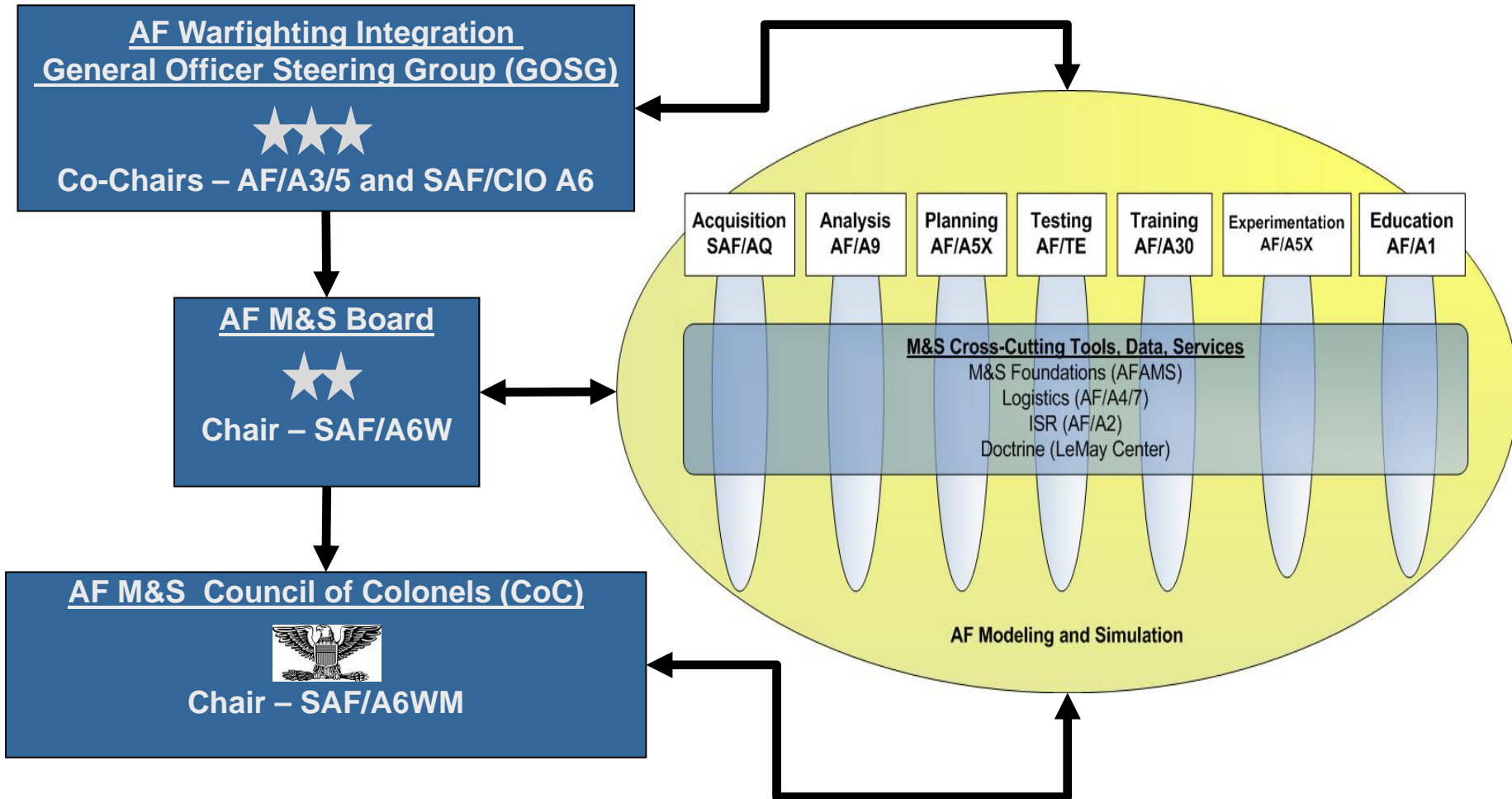

*Integrity - Service - Excellence*



# AF M&S Governance - Now

U.S. AIR FORCE

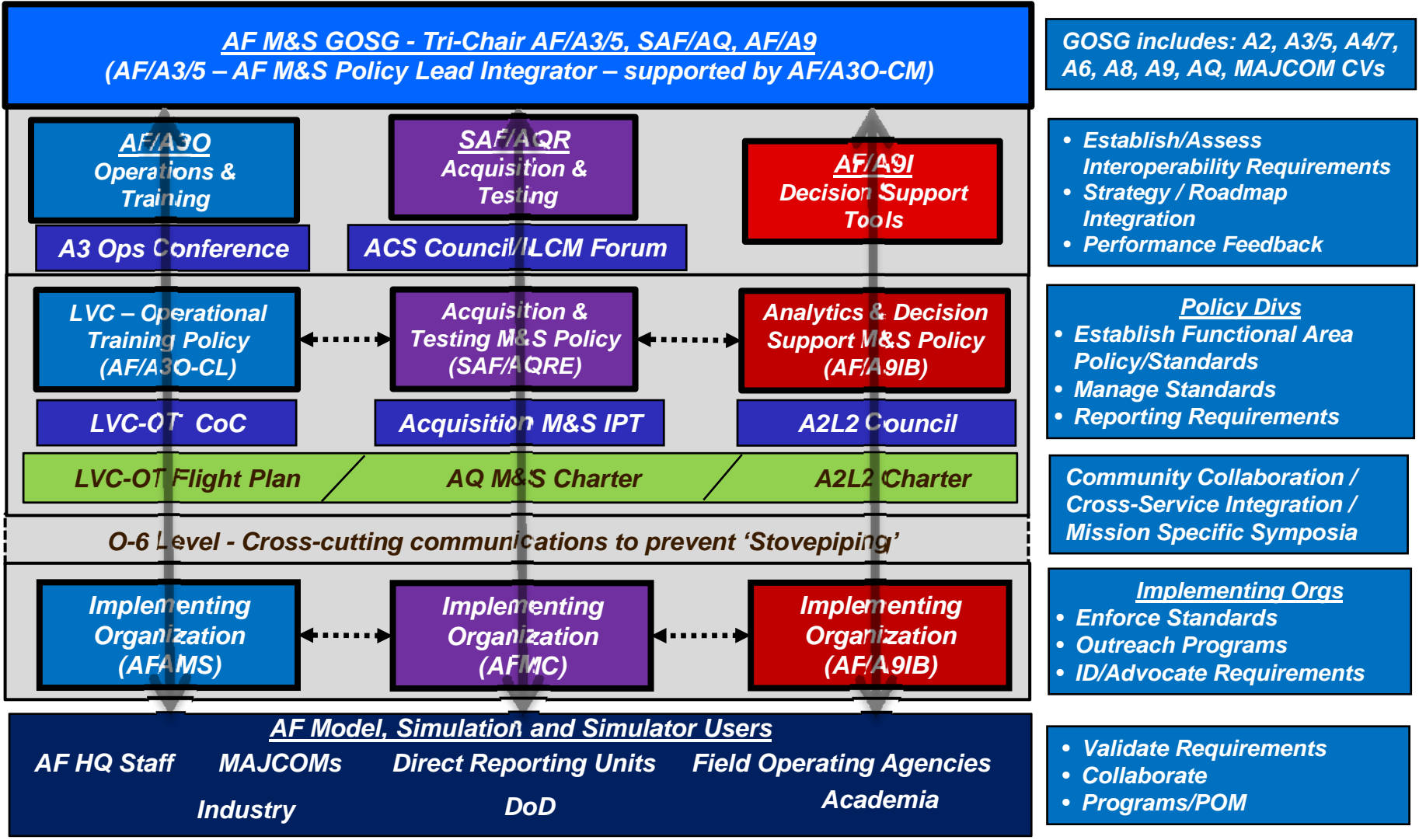



U.S. AIR FORCE

---

# *Questions?*



*Maximizing Warfighter Performance  
and Decision Making on the  
Tip of the Spear*

---

*Integrity - Service - Excellence*



U.S. AIR FORCE

# AFAMS OV-1



U.S. AIR FORCE

*Aim High... Fly-Fight-Win ...*



*By maximizing warfighter performance and decision making for all operations through seamless integration of live, virtual and constructive environments for operational training.*



**Best Ideas!**

*Effective  
Efficient  
Interoperable  
Cost Saving*



**NO!**

*Redundancies  
Waste  
Inefficiencies  
Cuts*

## AF LVC OPS TRAINING POLICY, RESOURCES, CAPABILITIES INTEGRATOR & IMPLEMENTER

- CAF
- MAF
- SOF
- Cyberspace
- C2 and ISR
- Space
- Agile Combat Support
- Partners
- ????

*SELECT PROGRAM  
MANAGEMENT  
M&S CAPABILITY  
INTEGRATION  
AF CAPABILITIES'  
ACCURATE SIMULATION*

*INFRASTRUCTURE  
DEVELOPMENT & MANAGEMENT  
KNOWLEDGE  
MANAGEMENT  
WORK FORCE  
DEVELOPMENT*

*POLICY, GUIDANCE & OVERSIGHT  
IMPLEMENTATION  
SCIENCE AND TECHNOLOGY  
ADVANCEMENT  
REQUIREMENTS  
CAPTURE AND ADVOCATION*



*Relevant... Effective... Get it done!*



Power Strip

Funding  
People  
Trust  
Policy



*Integrity - Service - Excellence*



U.S. AIR FORCE

# External Operations

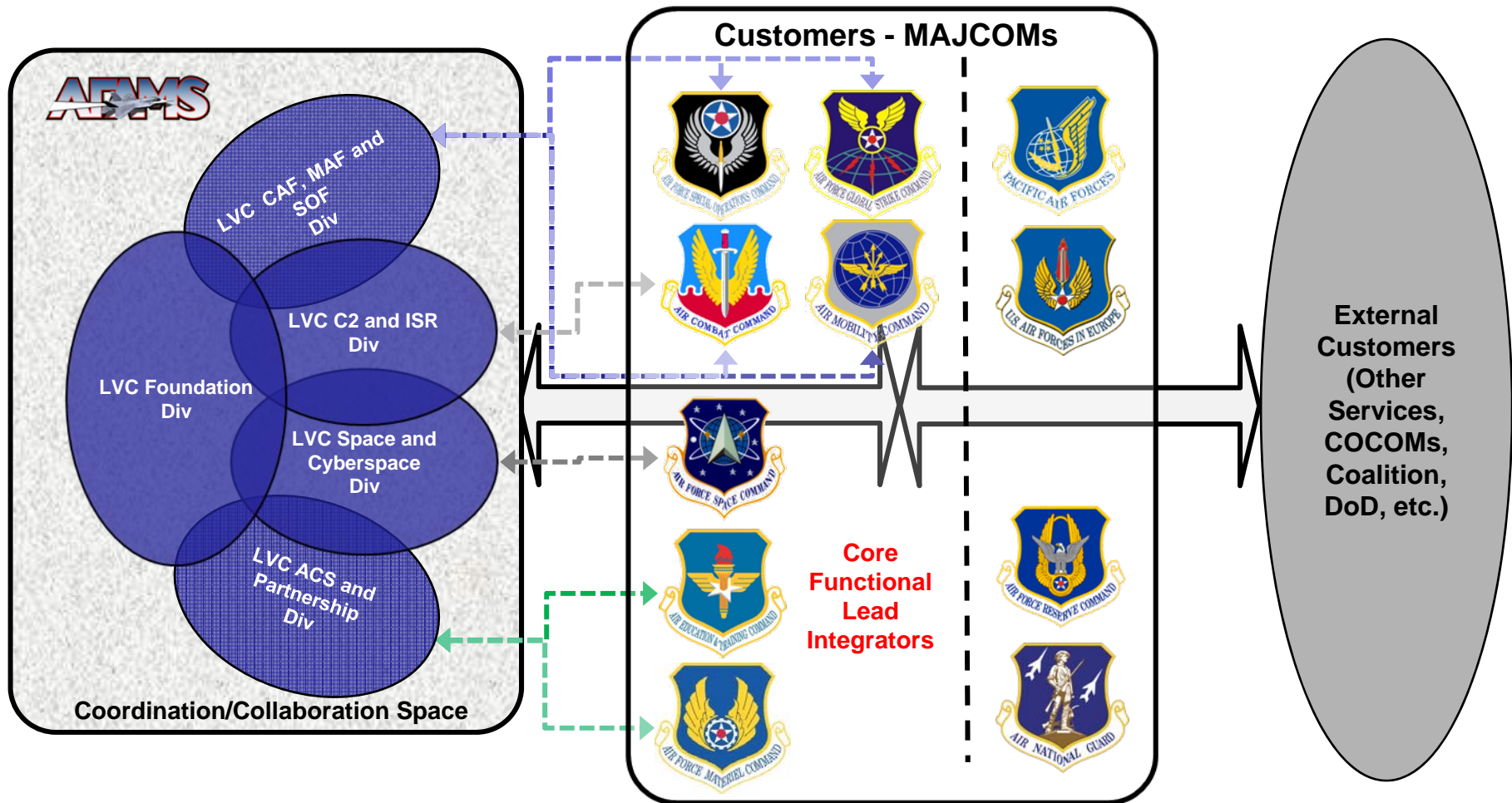

If confusing press here